

Do perform the time-analysis of the MPM network below

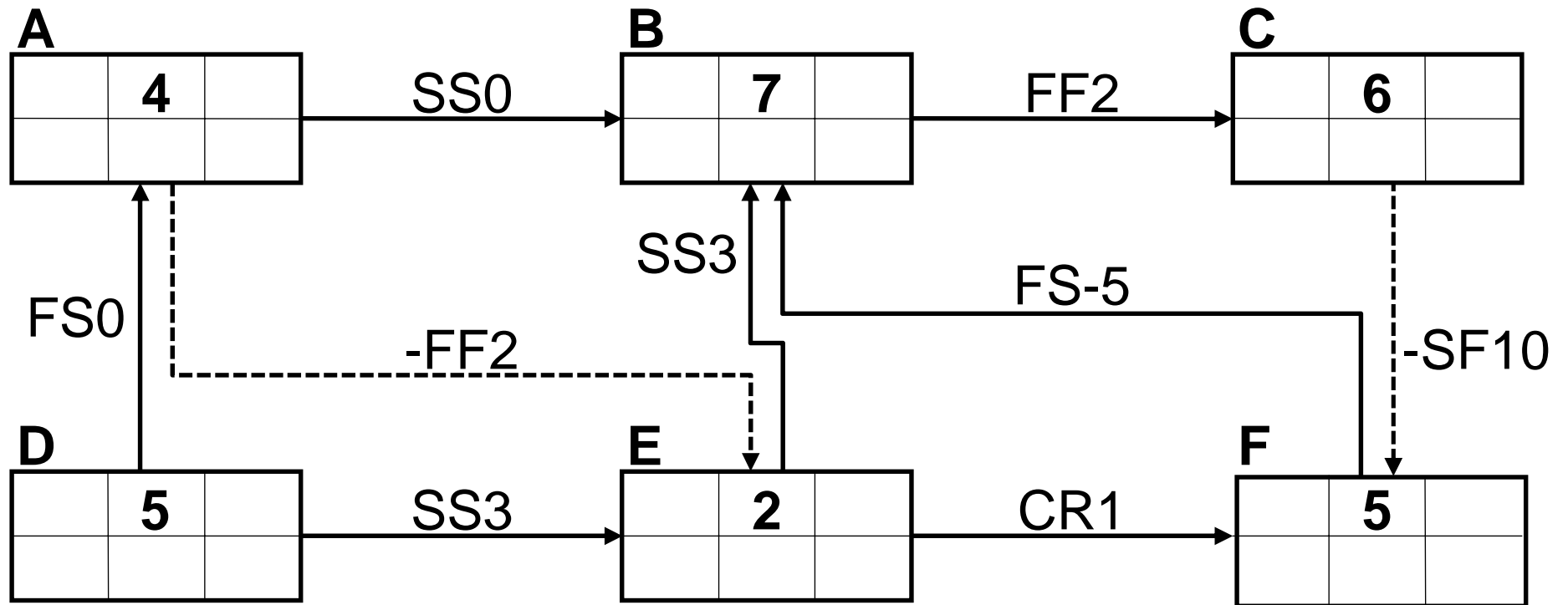

1.0 Substituting (exchanging) CR1 relation-pair by the dominant relation: SS1

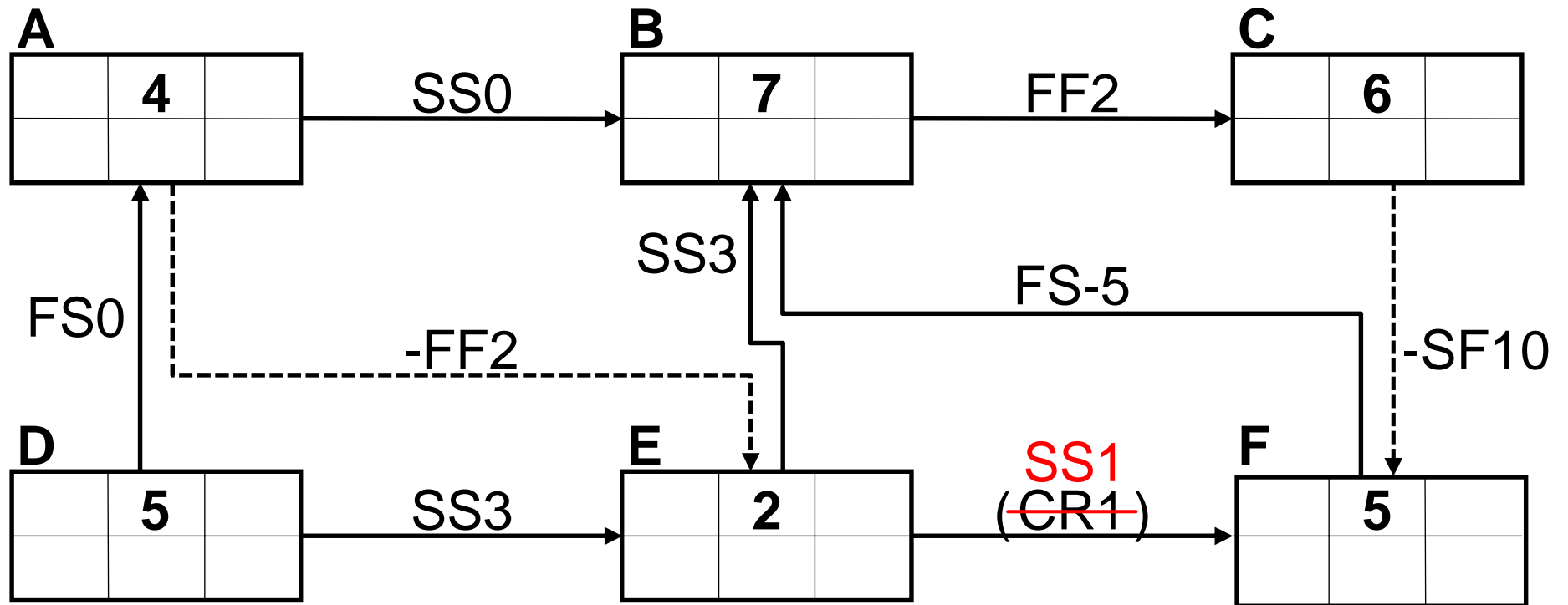

1.1 Identifying the starting point („Source”) and assigning „0” time-potential to it

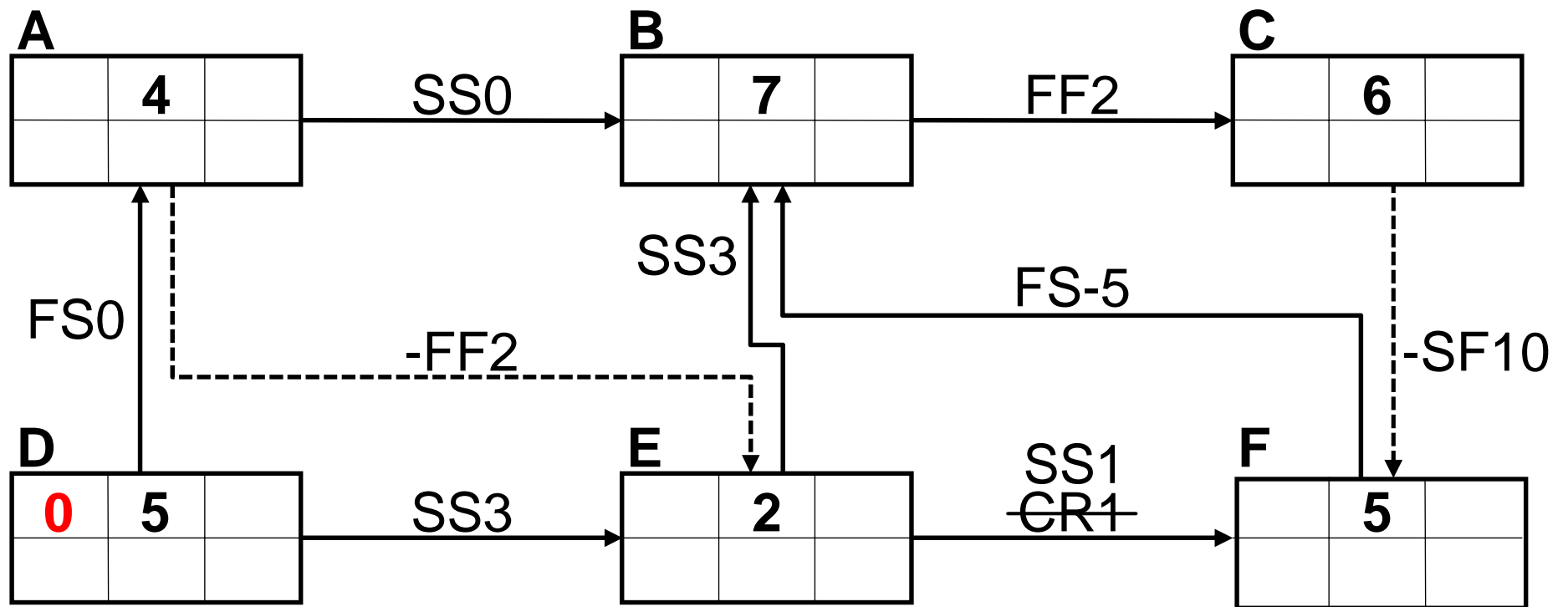

1.2 „If I knew the start time-potential of an activity of fixed duration, then I do know the finish of it too ...”

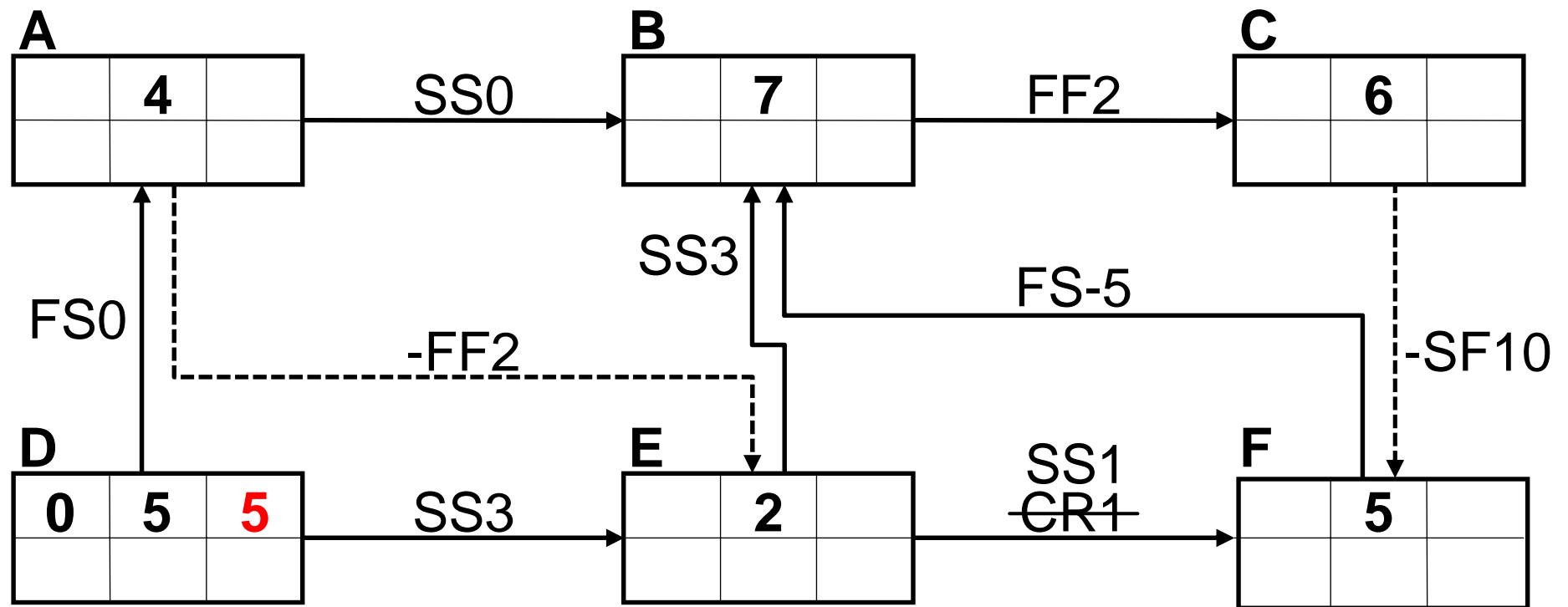

1.3 Progressing on like „rolling-up” in „by-arrow” direction

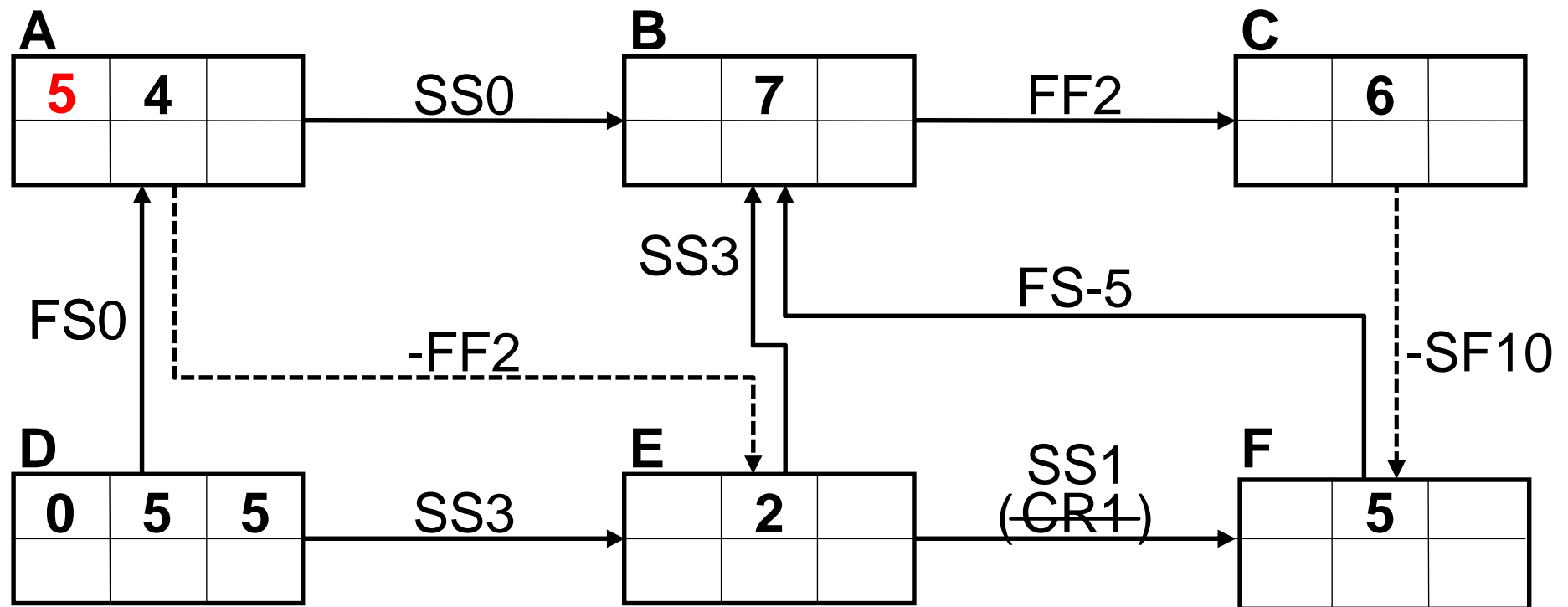

For progressing we have to choose an activity pointed at by arrows only originated from activities at which the early time-potentials have already been calculated.

1.4 „If I knew the start time-potential of an activity of fixed duration, then I do know the finish of it too ...”

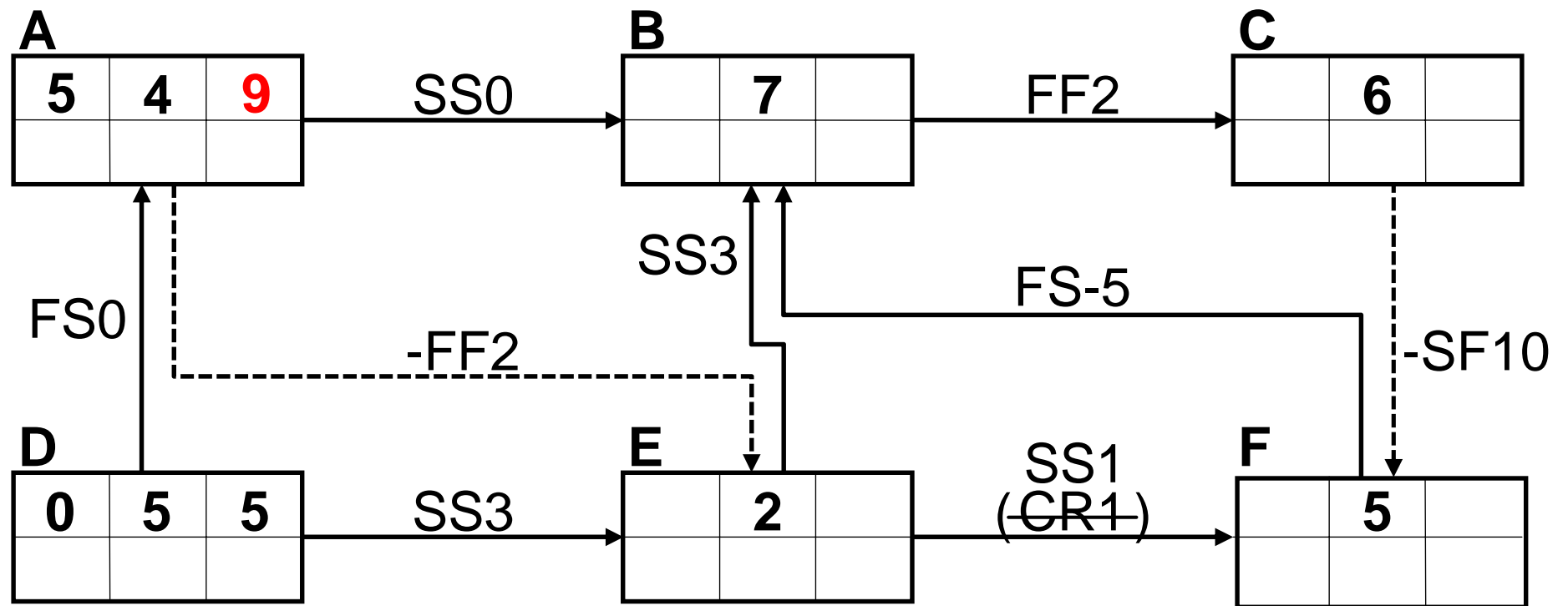

1.5 Progressing on like „rolling-up” in „by-arrow” direction

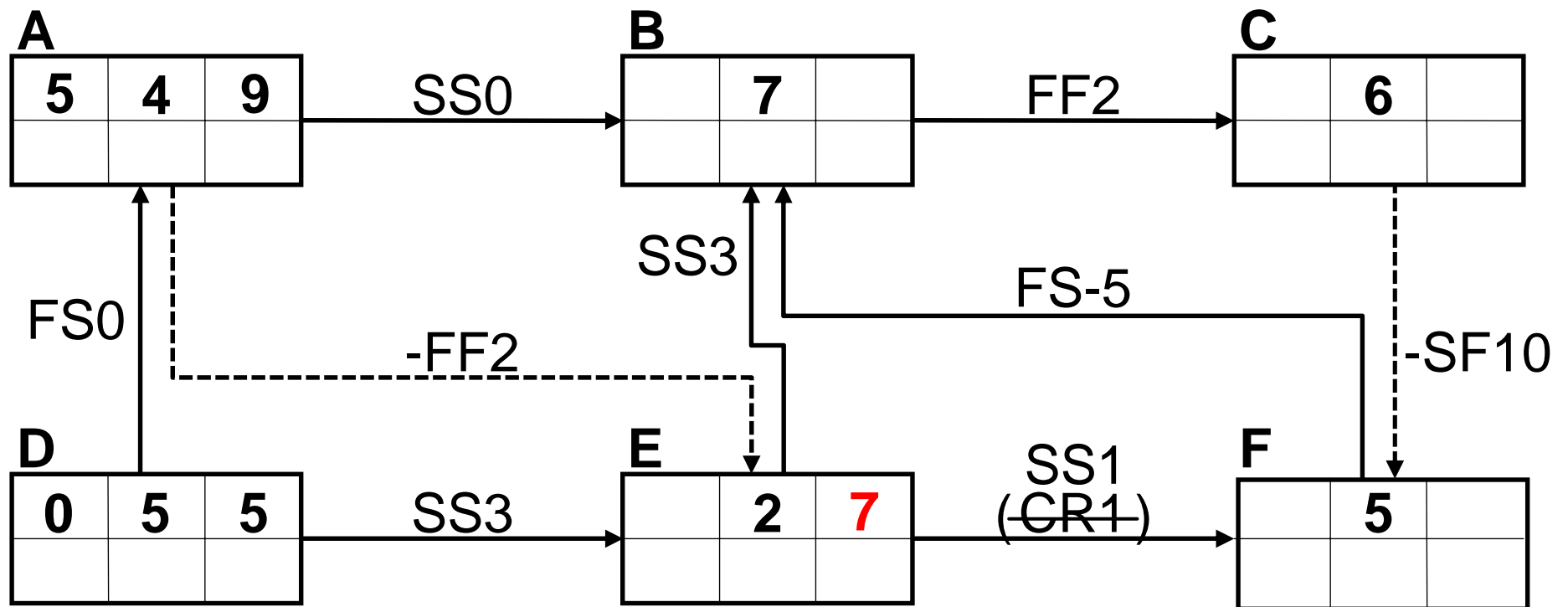

For progressing we have to choose an activity pointed at by arrows only originated from activities at which the early time-potentials have already been calculated. The minimum („earliest”) time-potential to be assigned must fit all „preceeding” relative boundaries (time-potential limitations).

1.6 „If I knew the finish time-potential of an activity of fixed duration, then I do know the start of it too ...”

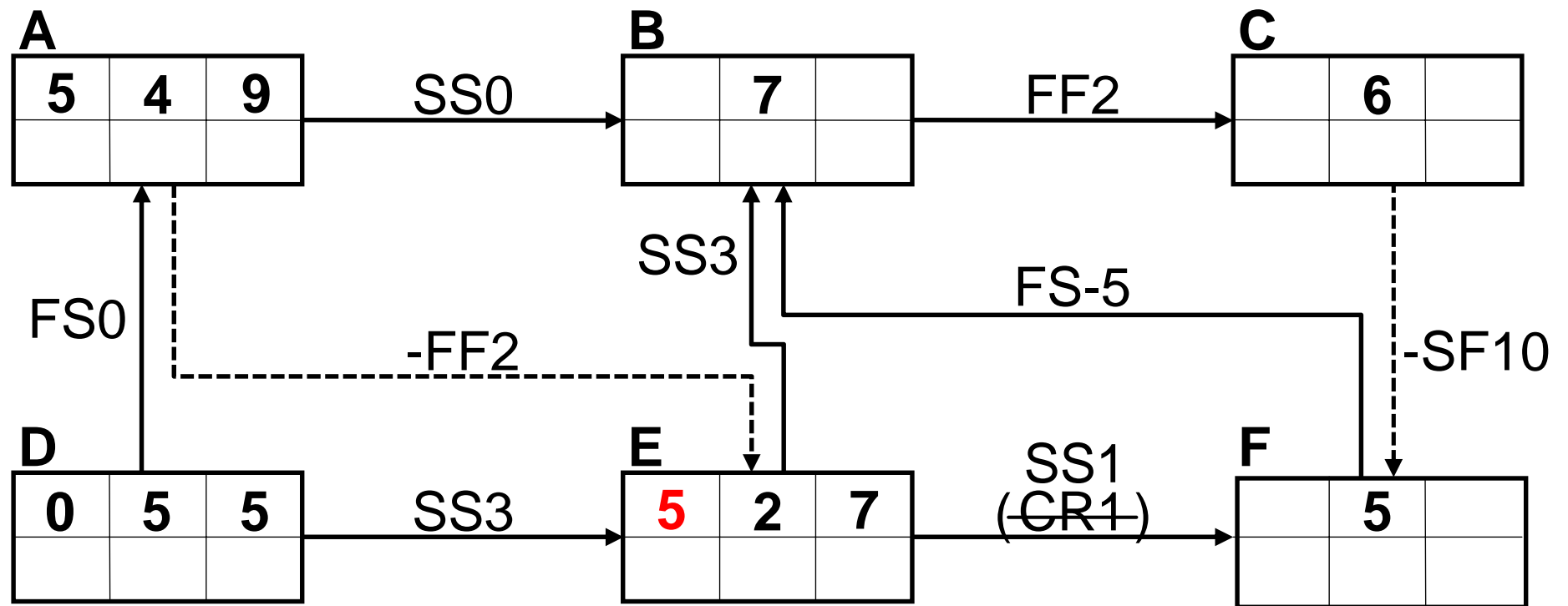

1.7 Progressing – temporarily – not considering any related maximum-typed relations involved in any loop (cycle)

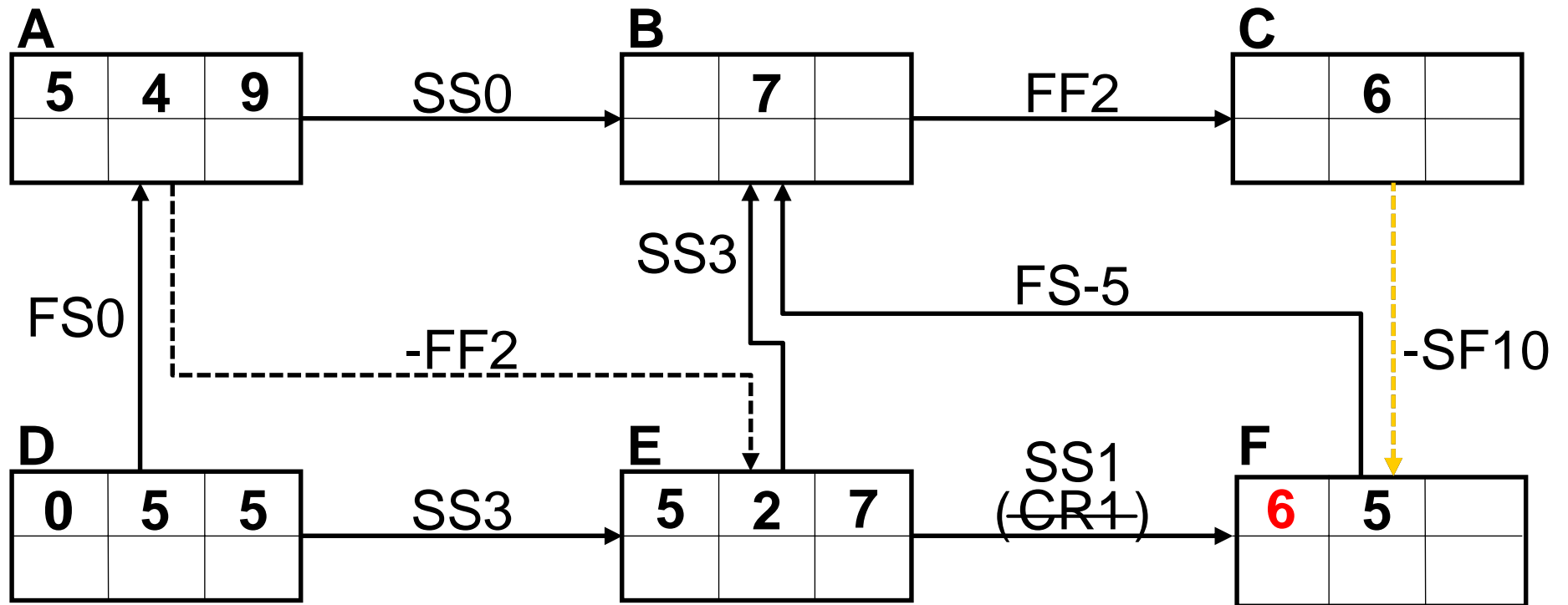

1.8 „If I knew the start time-potential of an activity of fixed duration, then I do know the finish of it too ...”

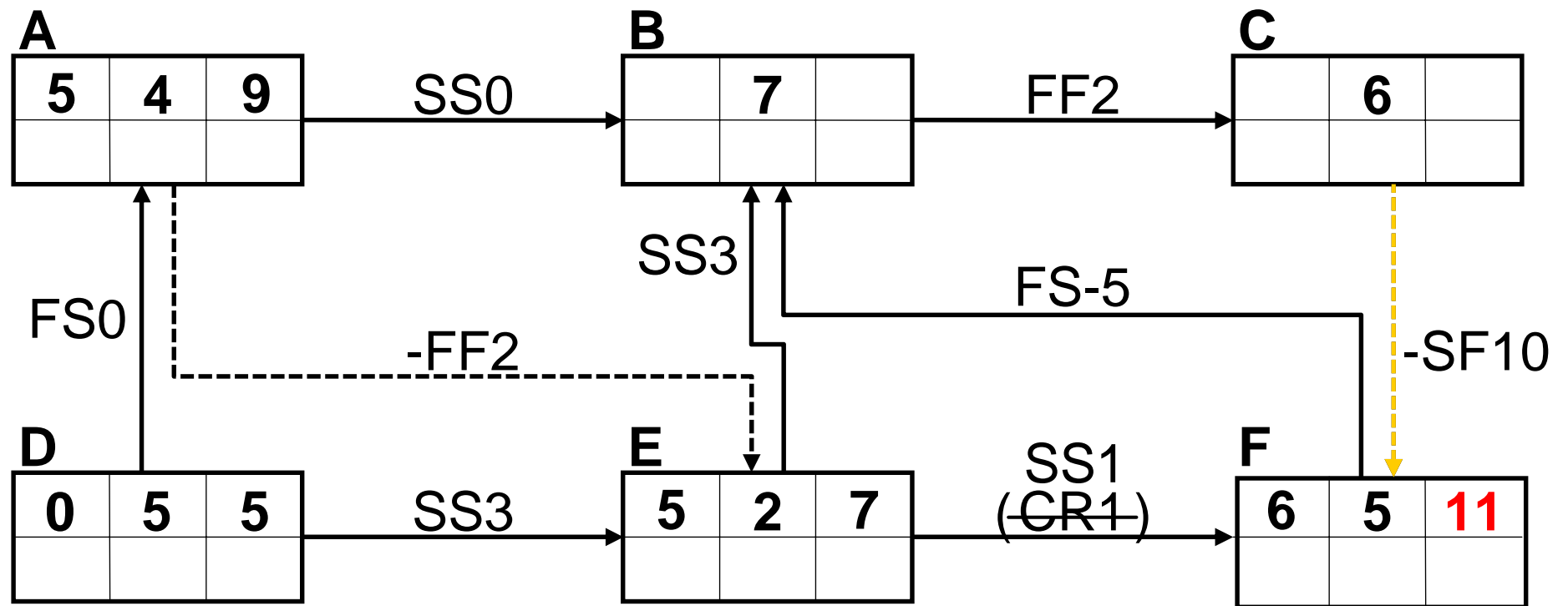

1.9 Progressing on like „rolling-up” in „by-arrow” direction

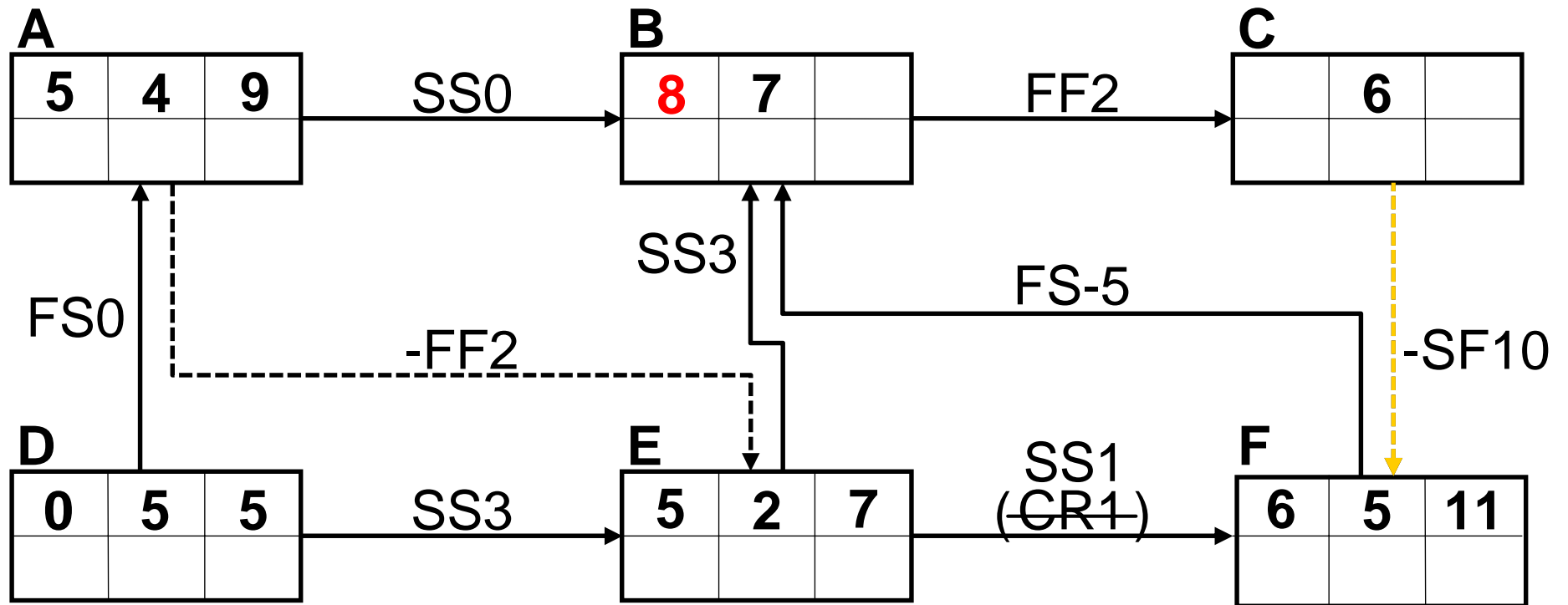

1.10 „If I knew the start time-potential of an activity of fixed duration, then I do know the finish of it too ...”

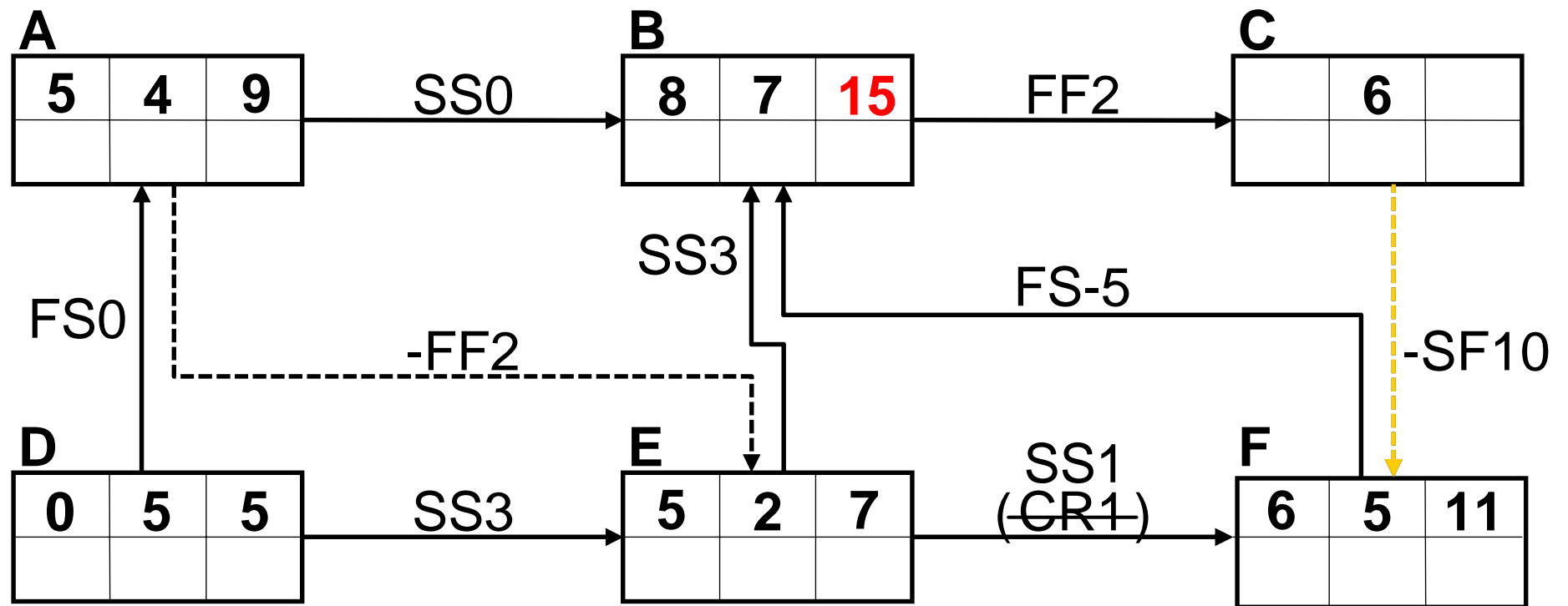

1.11 Progressing on like „rolling-up” in „by-arrow” direction

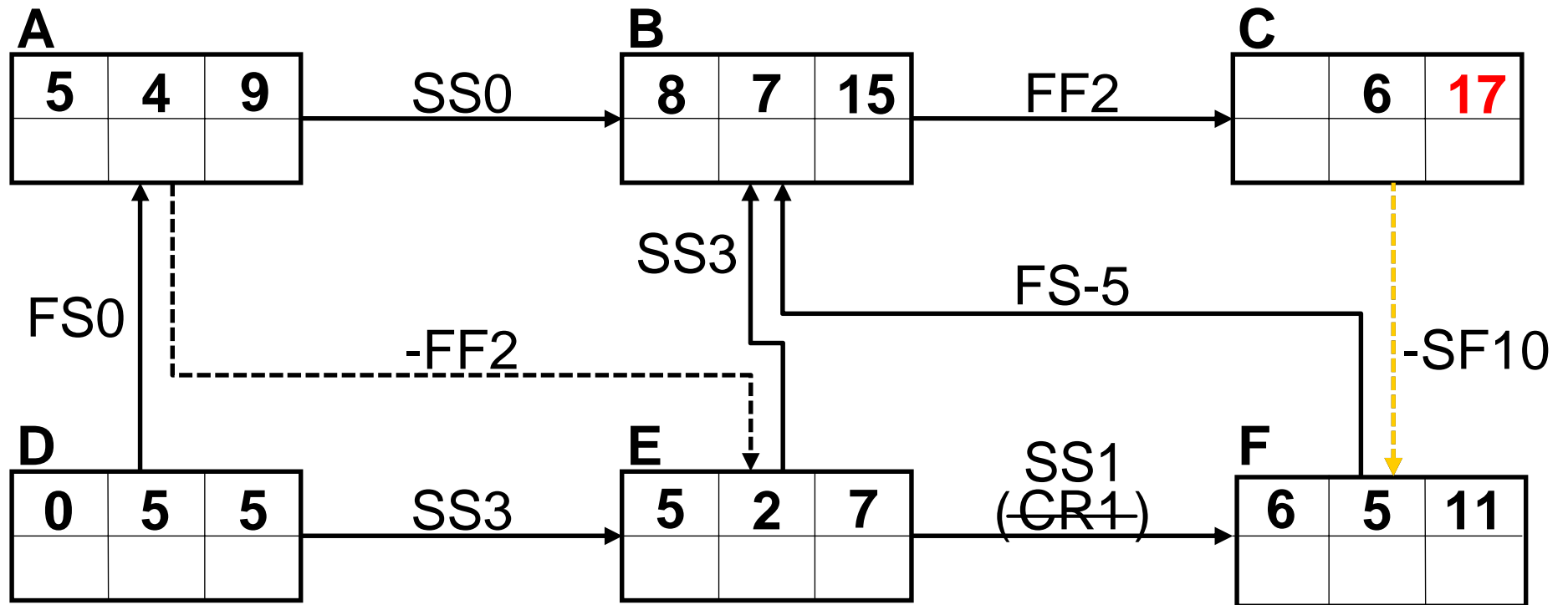

1.12 „If I knew the finish time-potential of an activity of fixed duration, then I do know the start of it too ...”

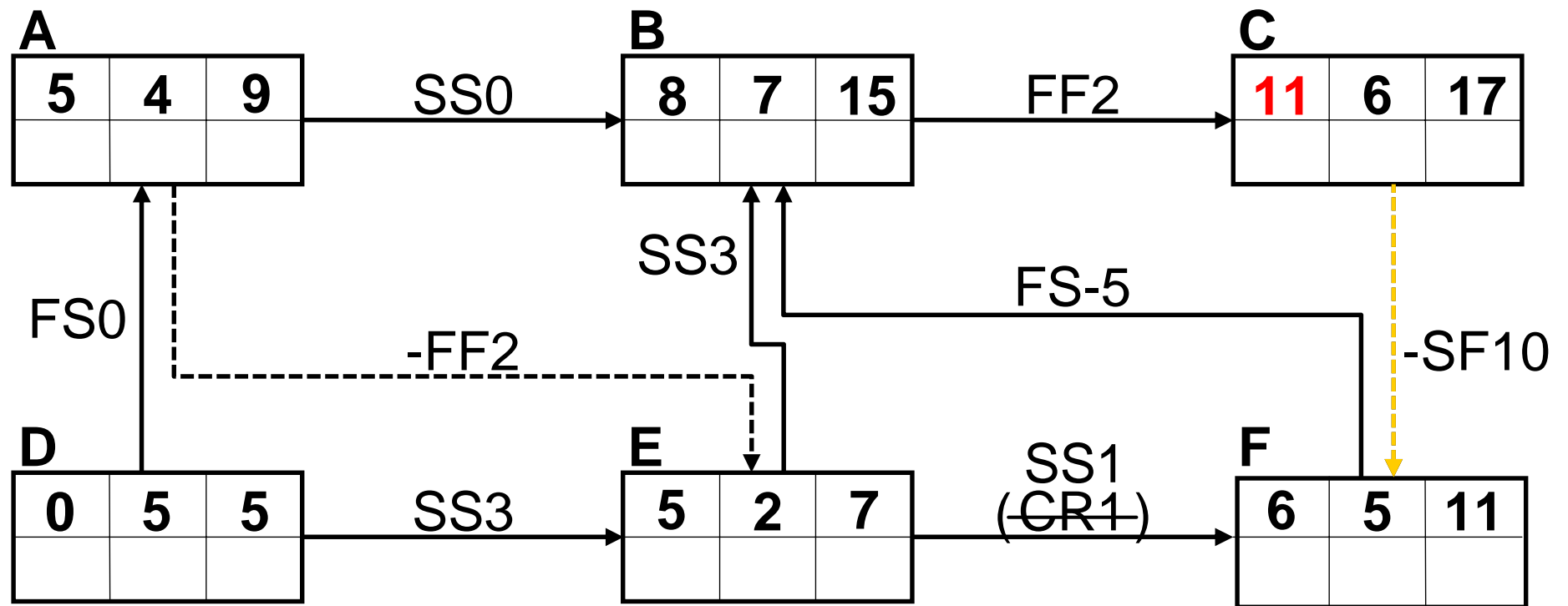

1.13 Checking validity of maximum-typed relation involved in the loop and had been – temporarily – not considered.

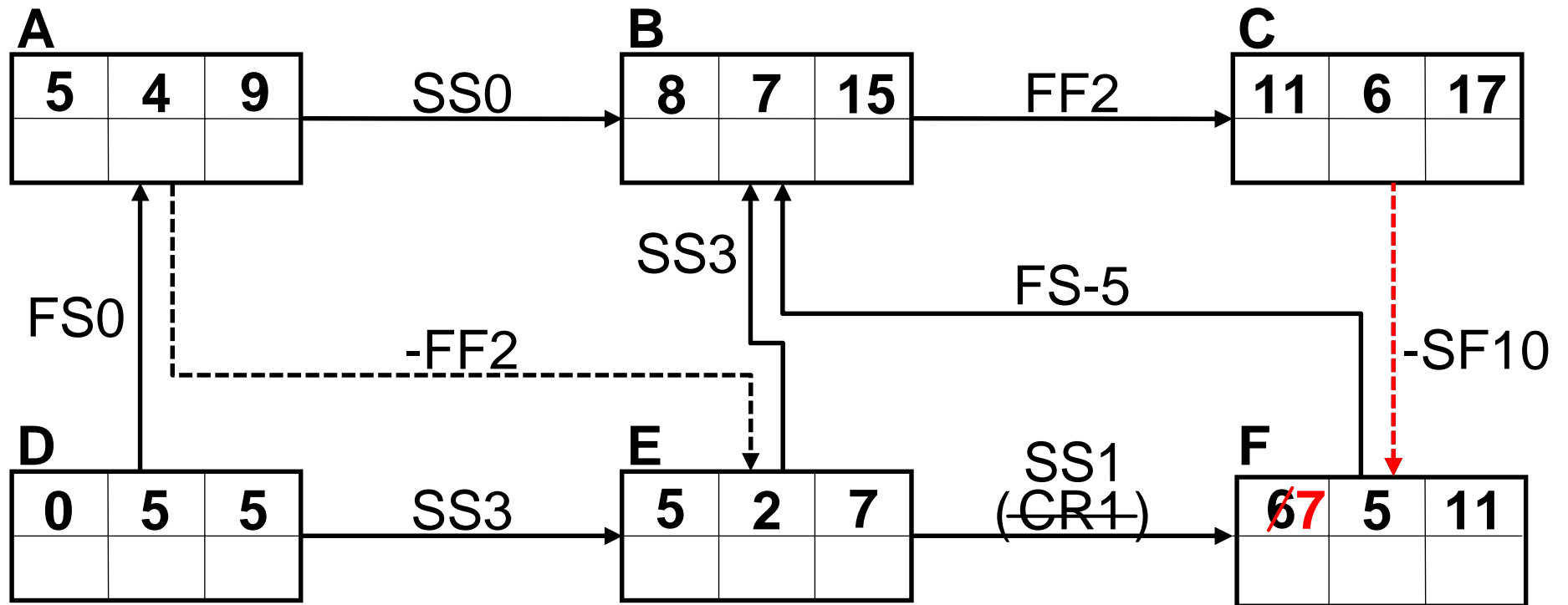

1.14 „If I knew the start time-potential of an activity of fixed duration, then I do know the finish of it too ...”

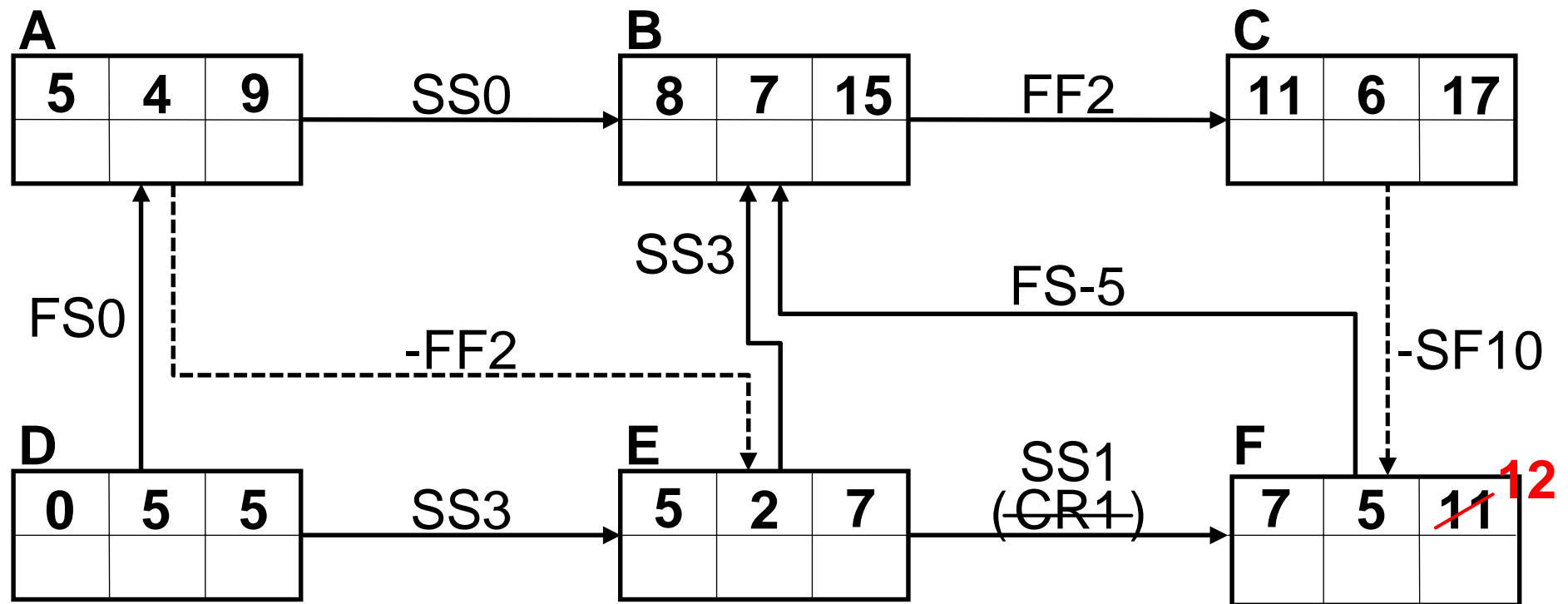

1.15 Checking validity of all the limitations (relations, „arrows”) involved in the loop (cycle)

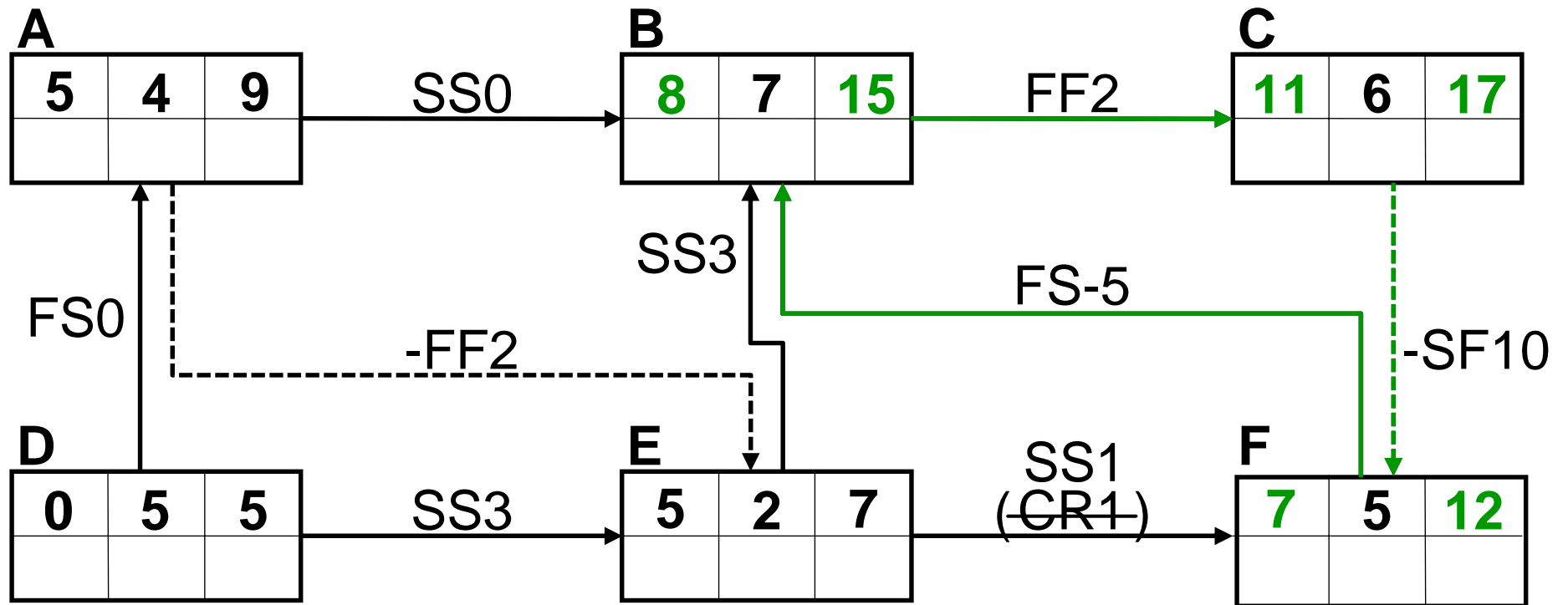

2.1 „Let the latest finish time-potential of the finishing (closing) activity be equal to its early finish time-potential”

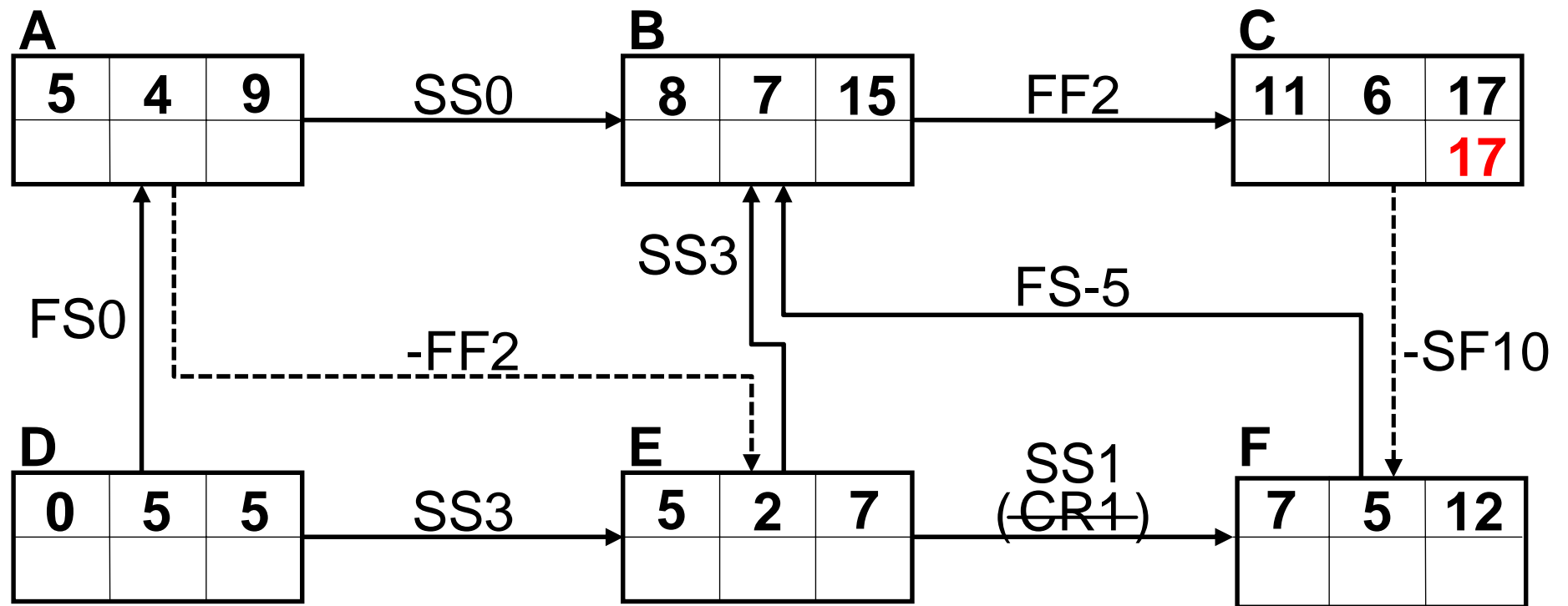

2.2 „If I knew the finish time-potential of an activity of fixed duration, then I do know the start of it too ...”

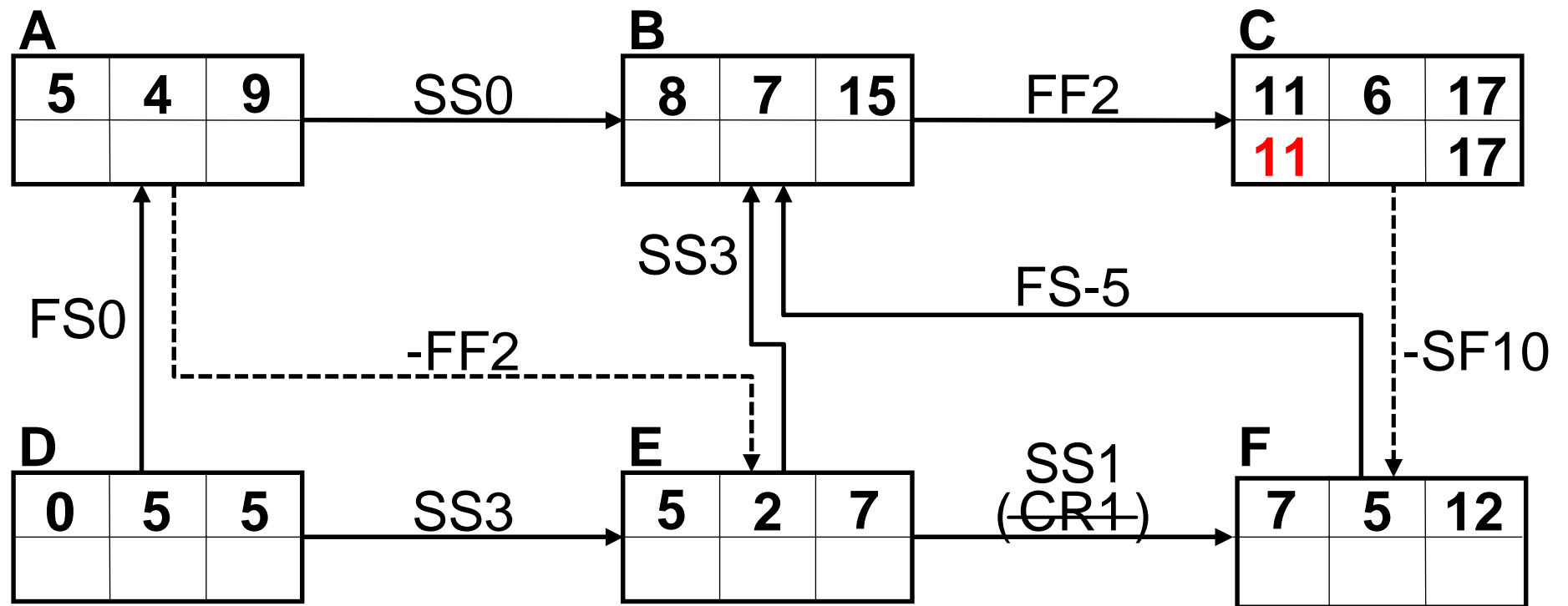

2.3 Progressing – temporarily – not considering any related maximum-typed relations involved in any loop (cycle)

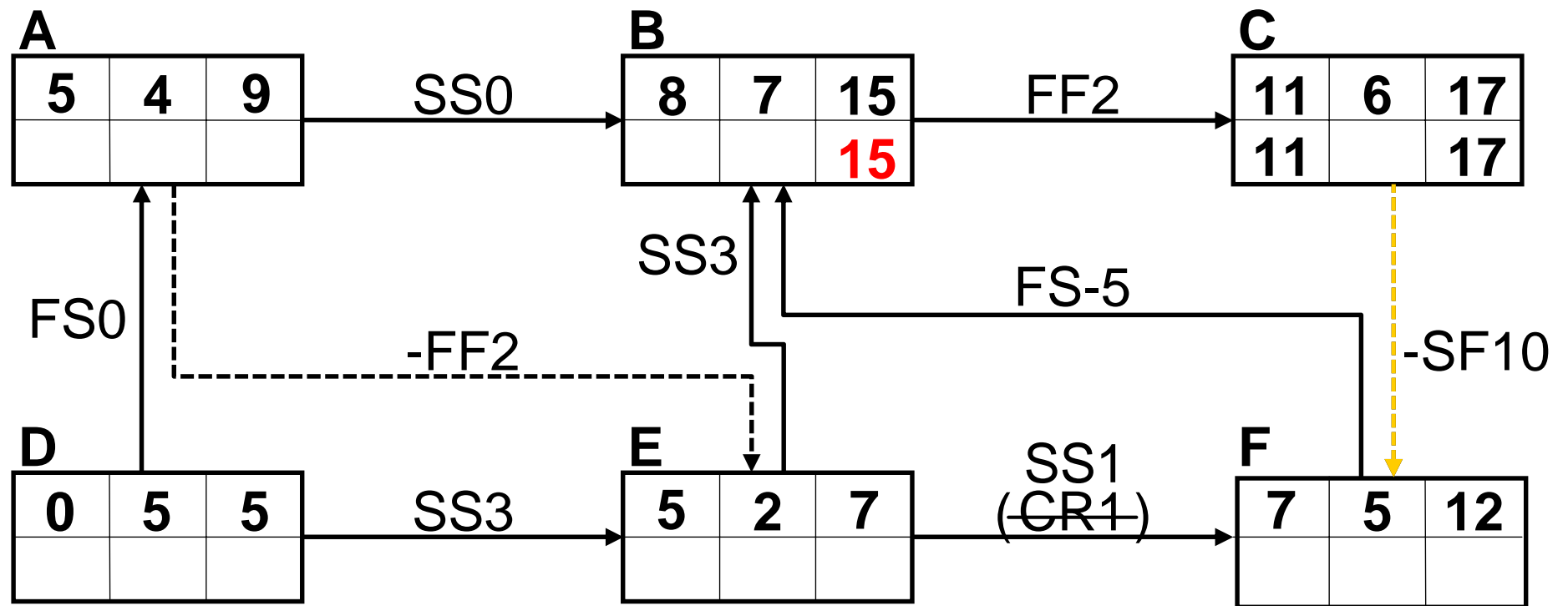

2.4 „If I knew the finish time-potential of an activity of fixed duration, then I do know the start of it too ...”

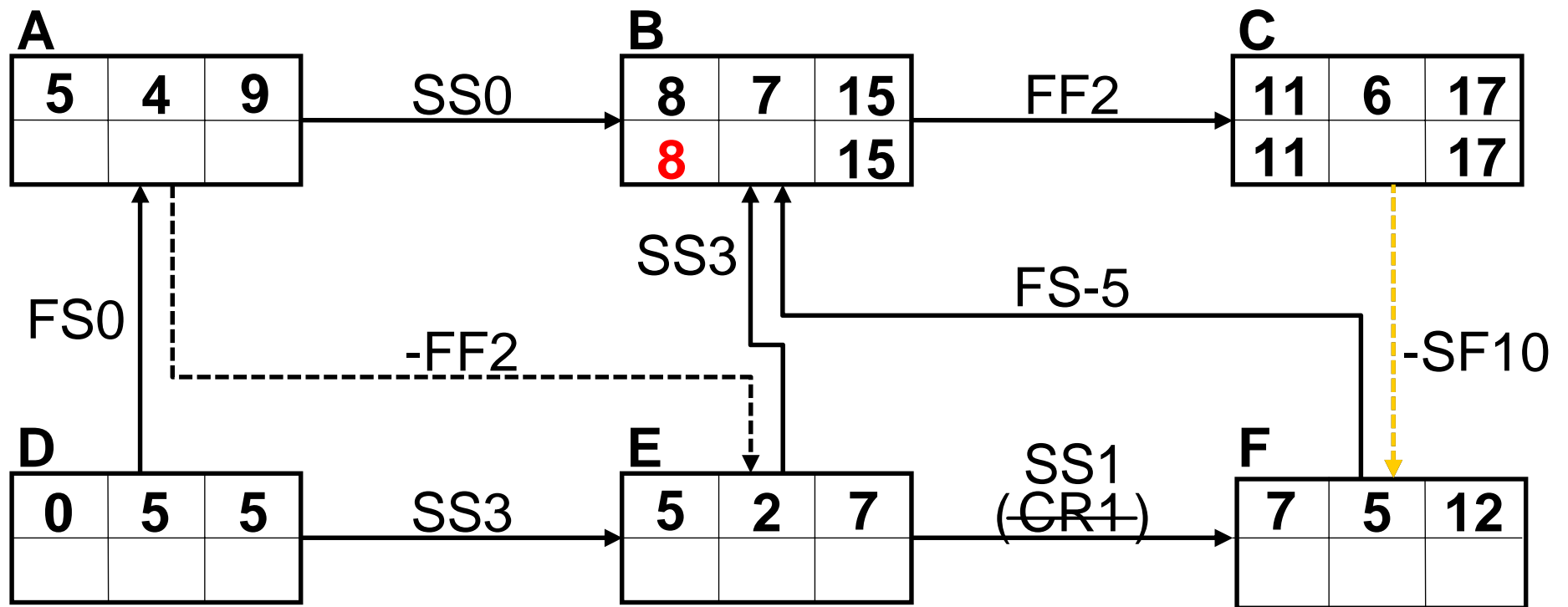

2.5 Progressing on like „rolling-up” in „counter-arrow” direction

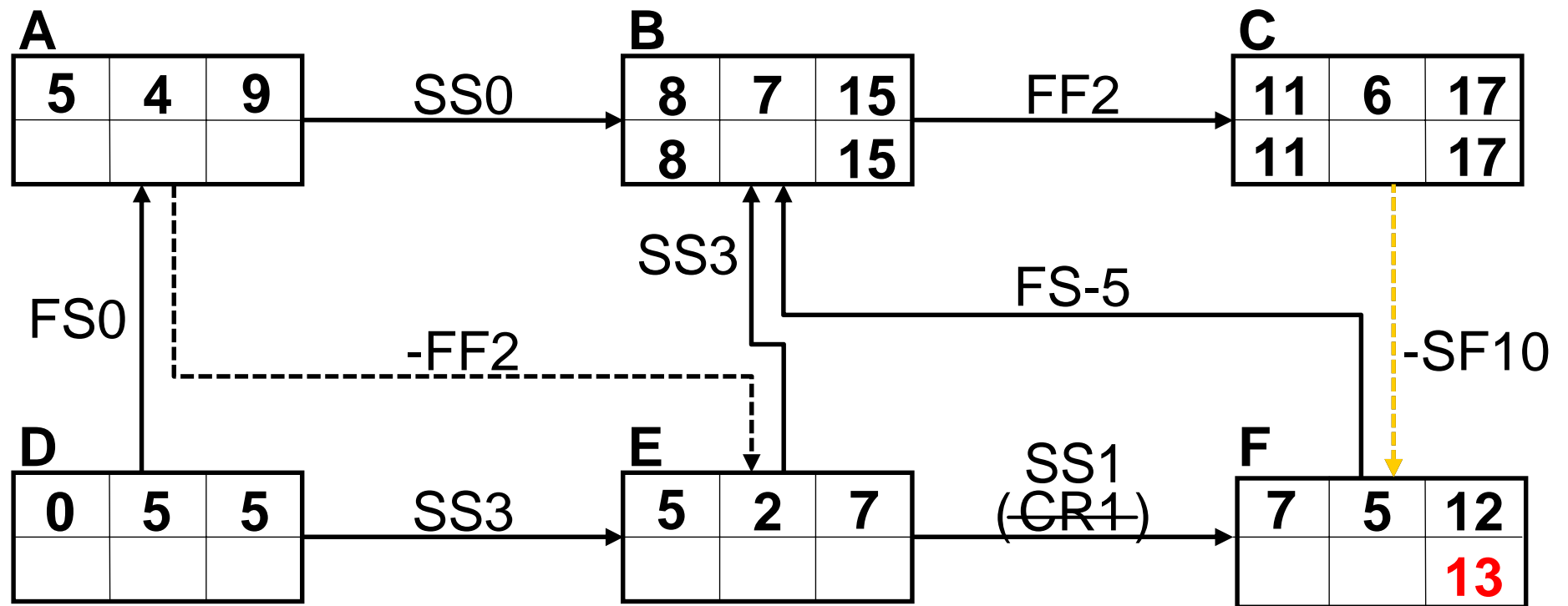

2.6 „If I knew the finish time-potential of an activity of fixed duration, then I do know the start of it too ...”

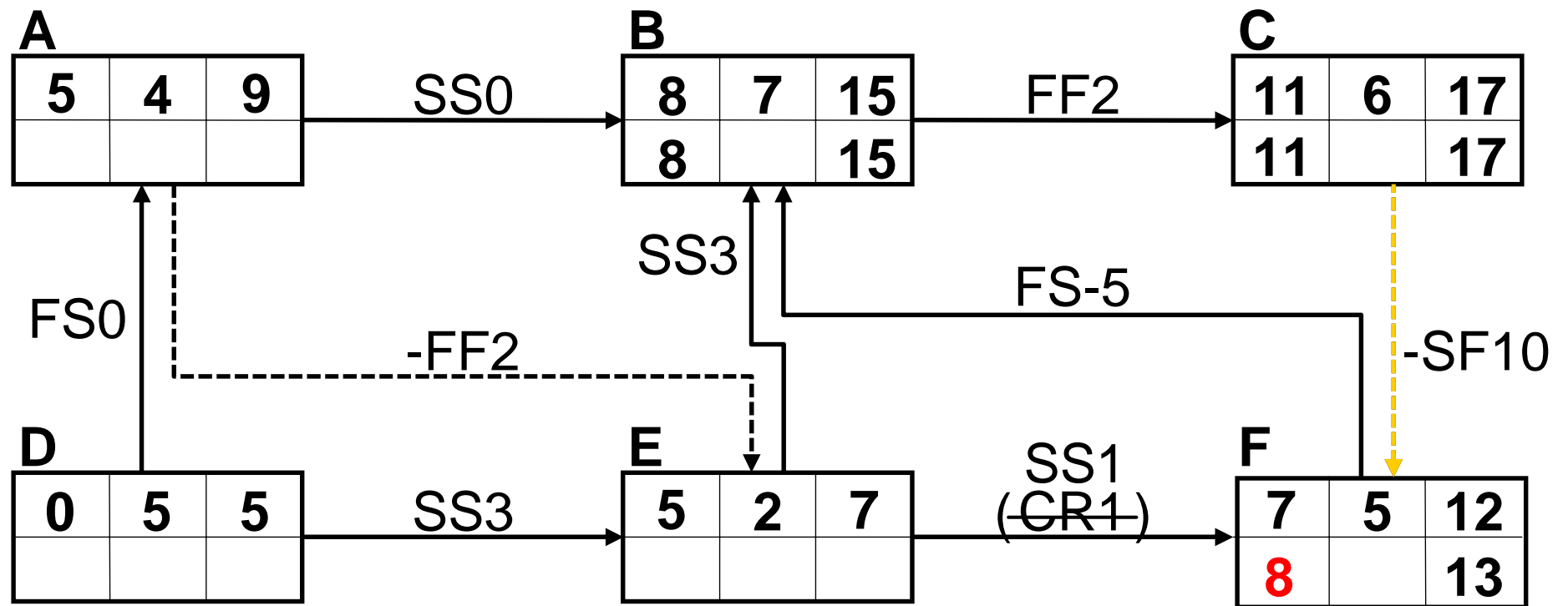

2.7 Checking validity of maximum-typed relation involved in the loop and had been – temporarily – not considered.

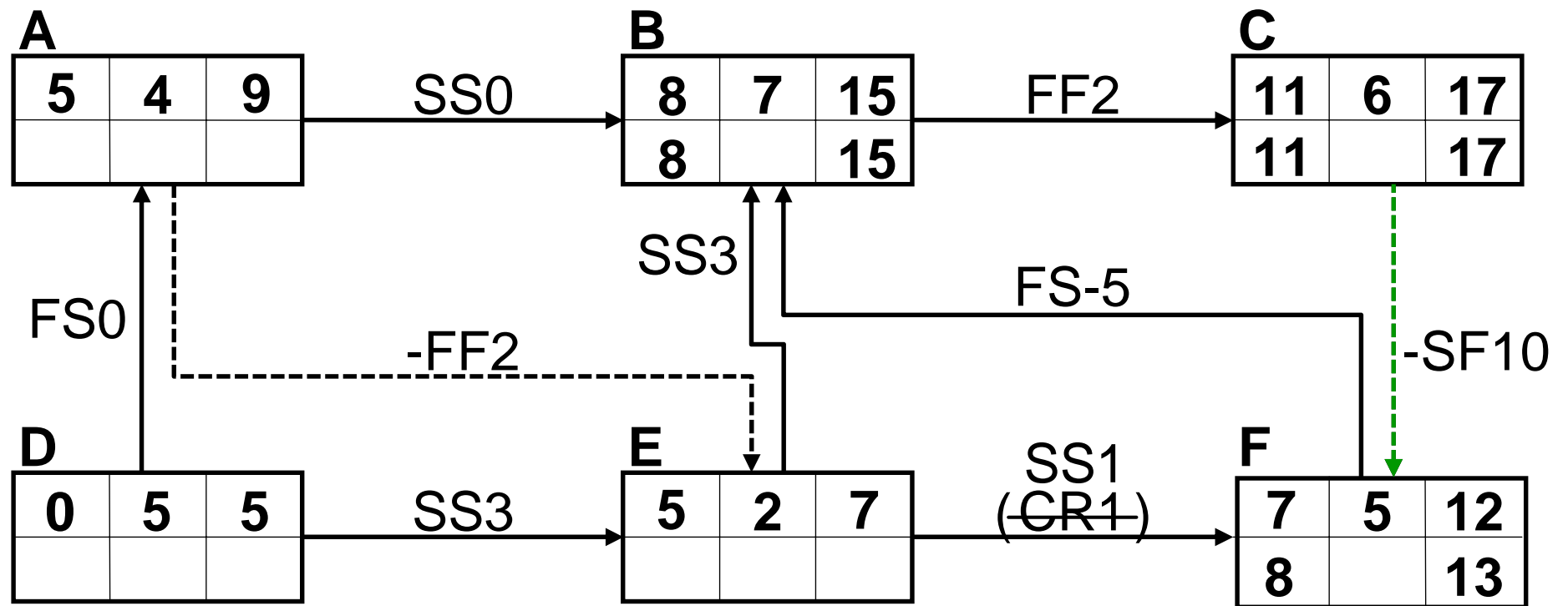

2.8 Progressing on like „rolling-up” in „counter-arrow” direction

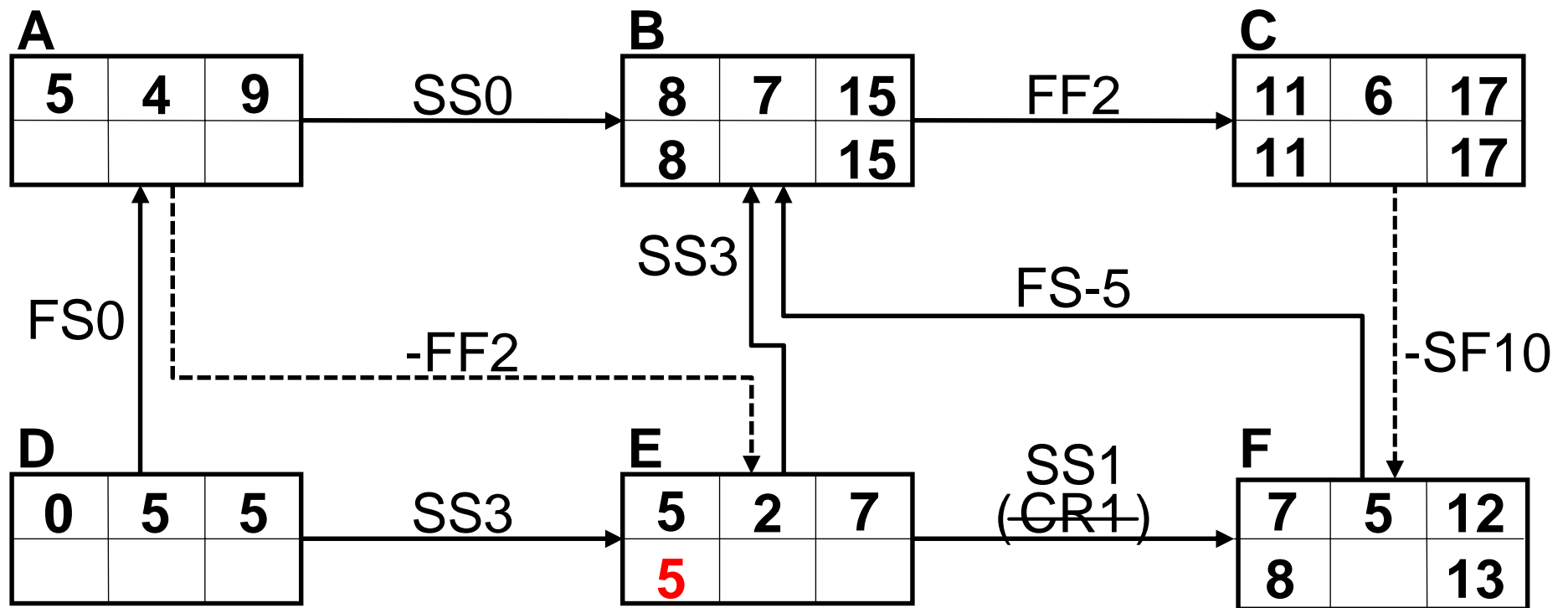

For progressing we have to choose an activity pointing its arrows at activities only at which the late time-potentials have already been calculated. The maximum („latest”) time-potential to be assigned must fit all „succeeding” relative boundaries (time-potential limitations).

2.9 „If I knew the start time-potential of an activity of fixed duration, then I do know the finish of it too ...”

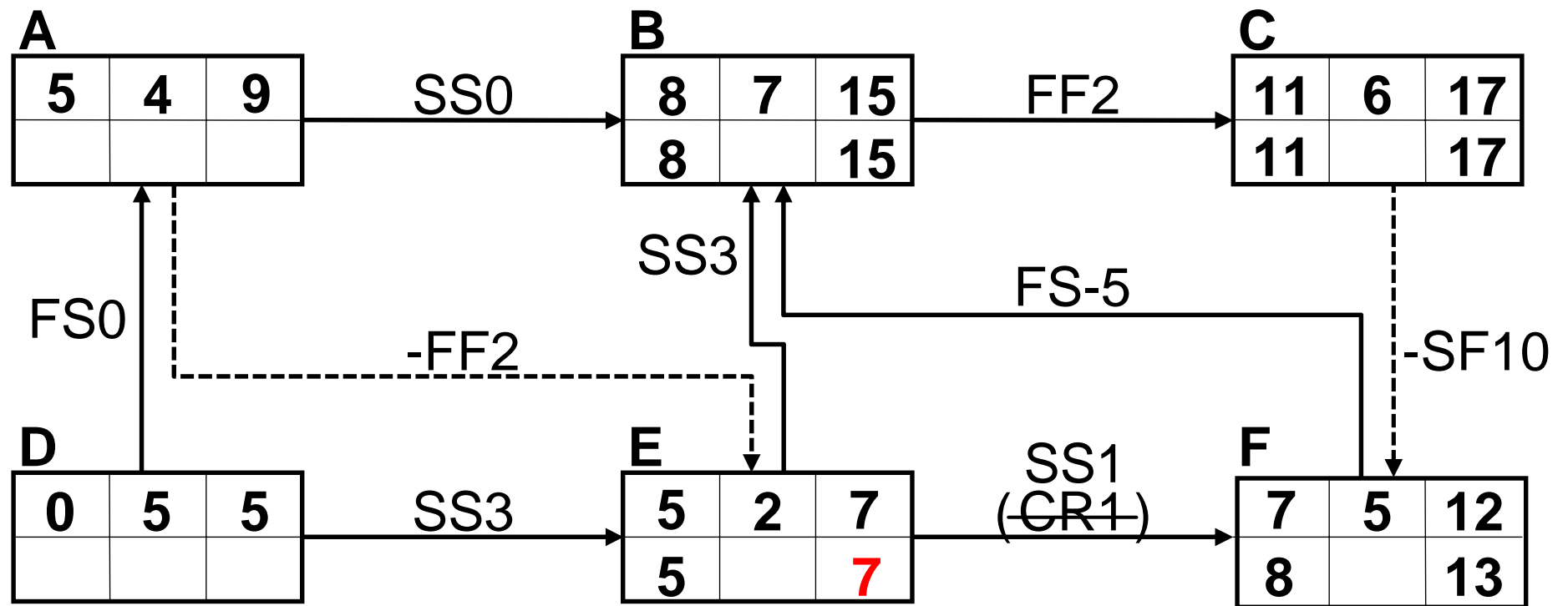

2.10 Progressing on like „rolling-up” in „counter-arrow” direction

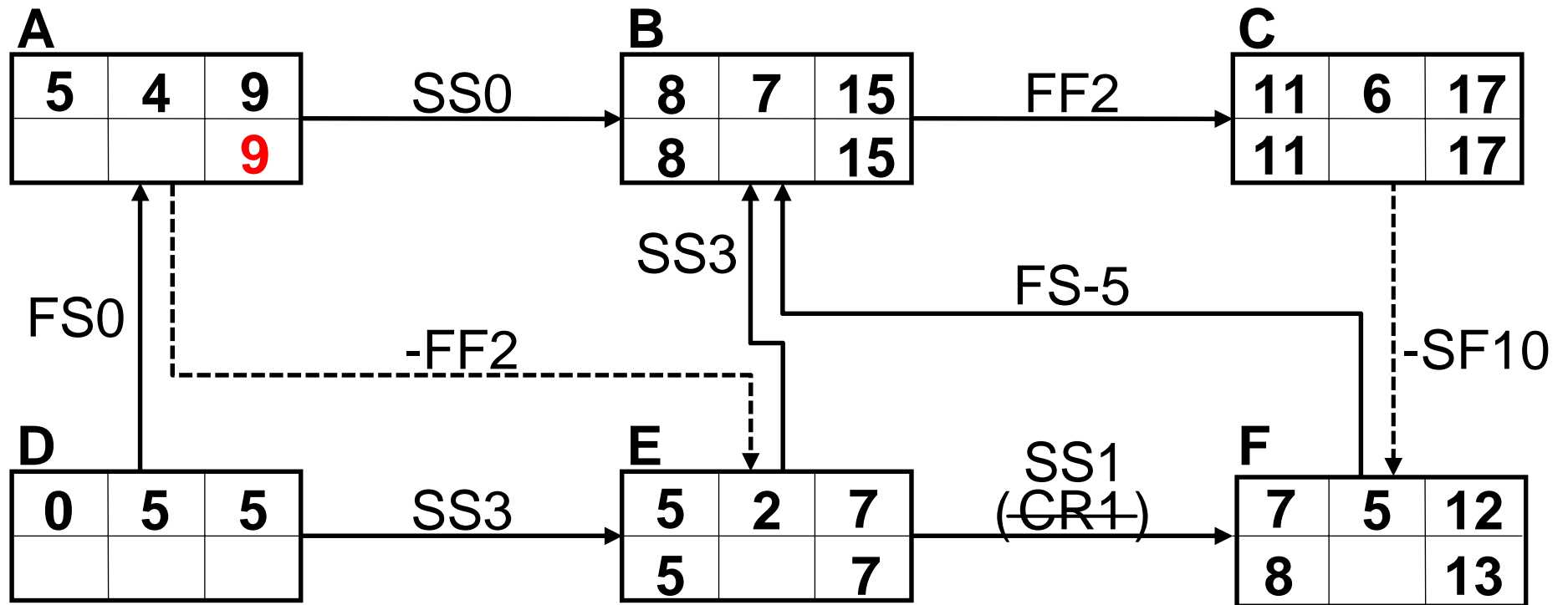

2.11 „If I knew the finish time-potential of an activity of fixed duration, then I do know the start of it too ...”

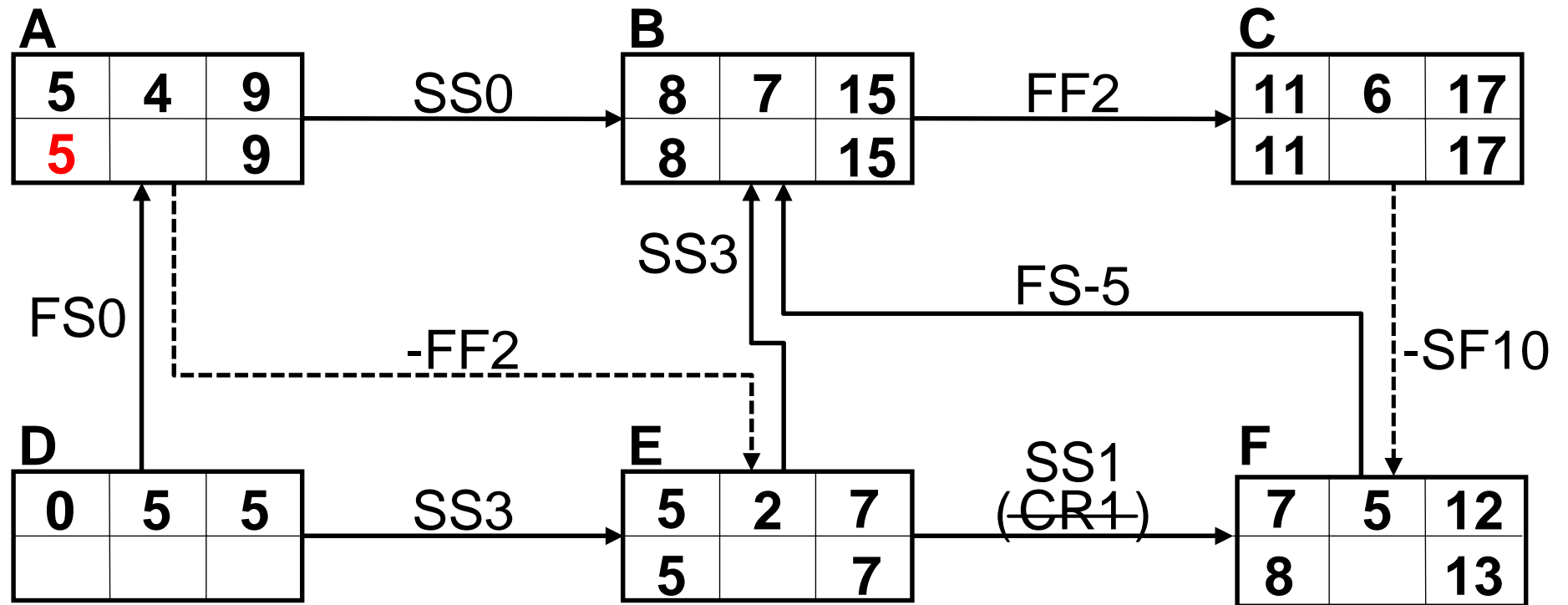

2.12 Progressing on like „rolling-up” in „counter-arrow” direction

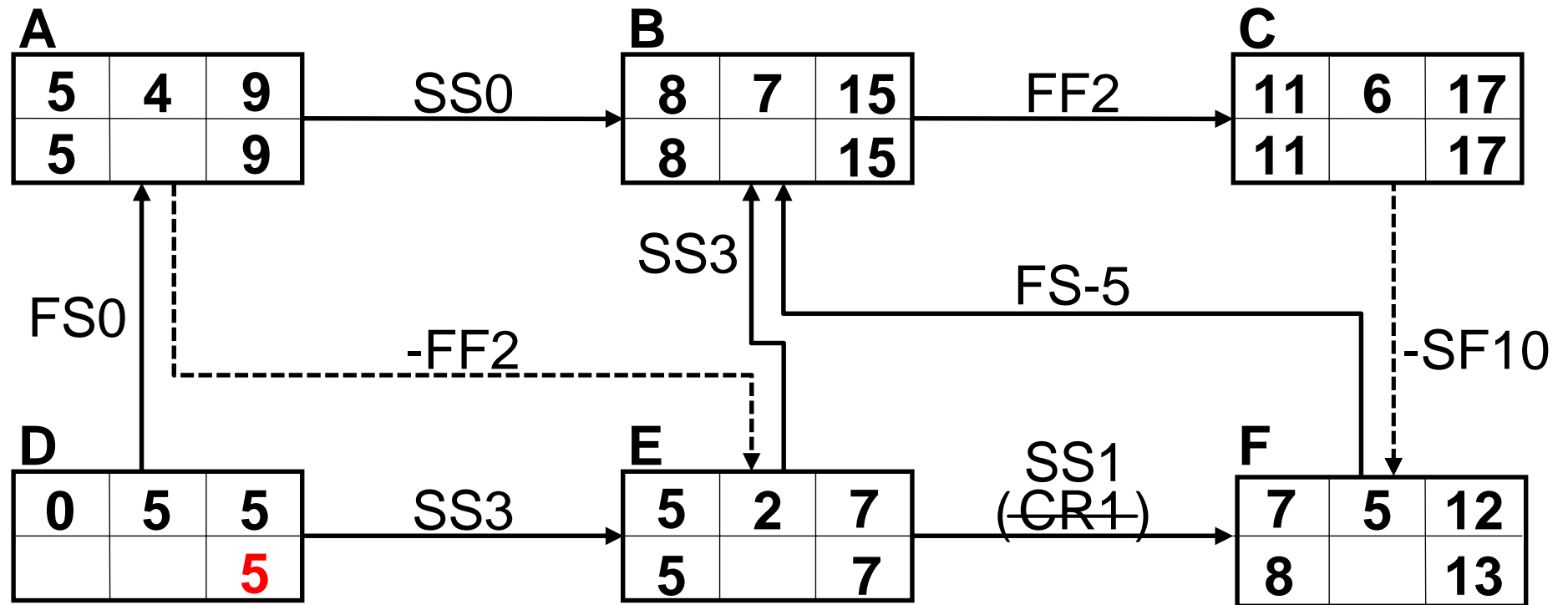

2.13 „If I knew the finish time-potential of an activity of fixed duration, then I do know the start of it too ...”

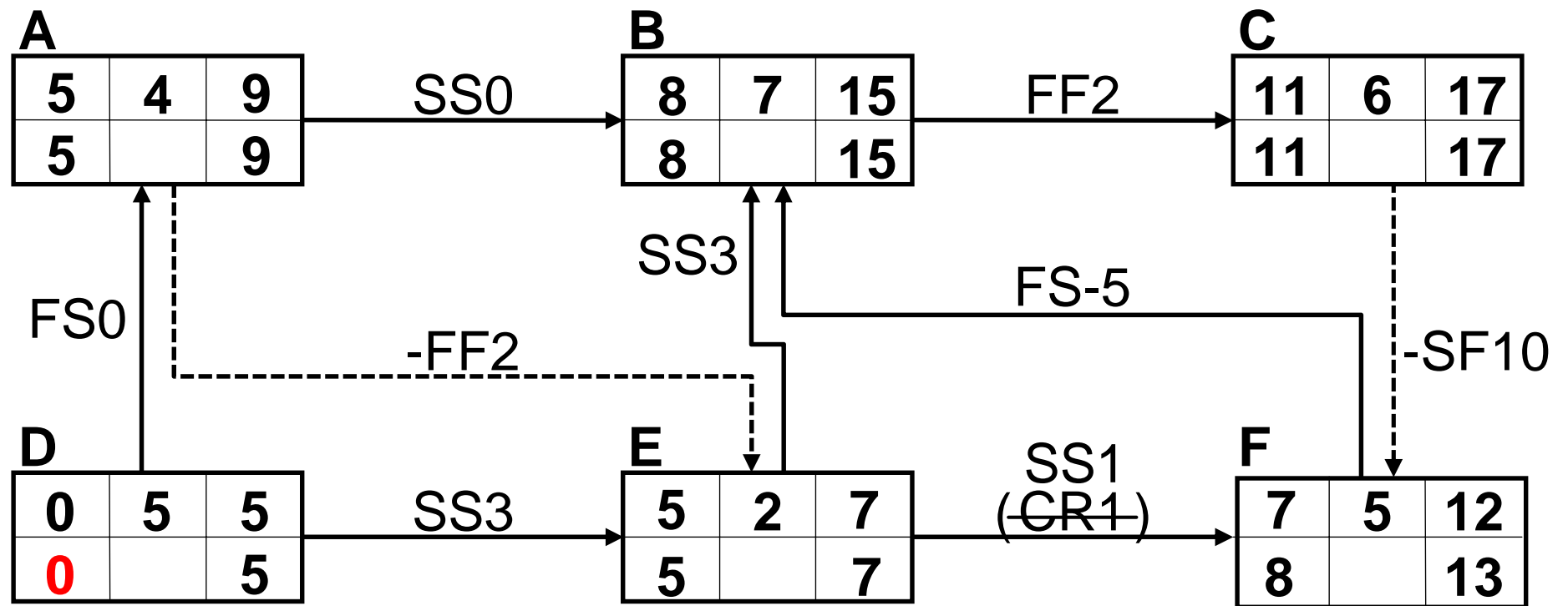

3.1 Calculating total floats and identifying the critical activities

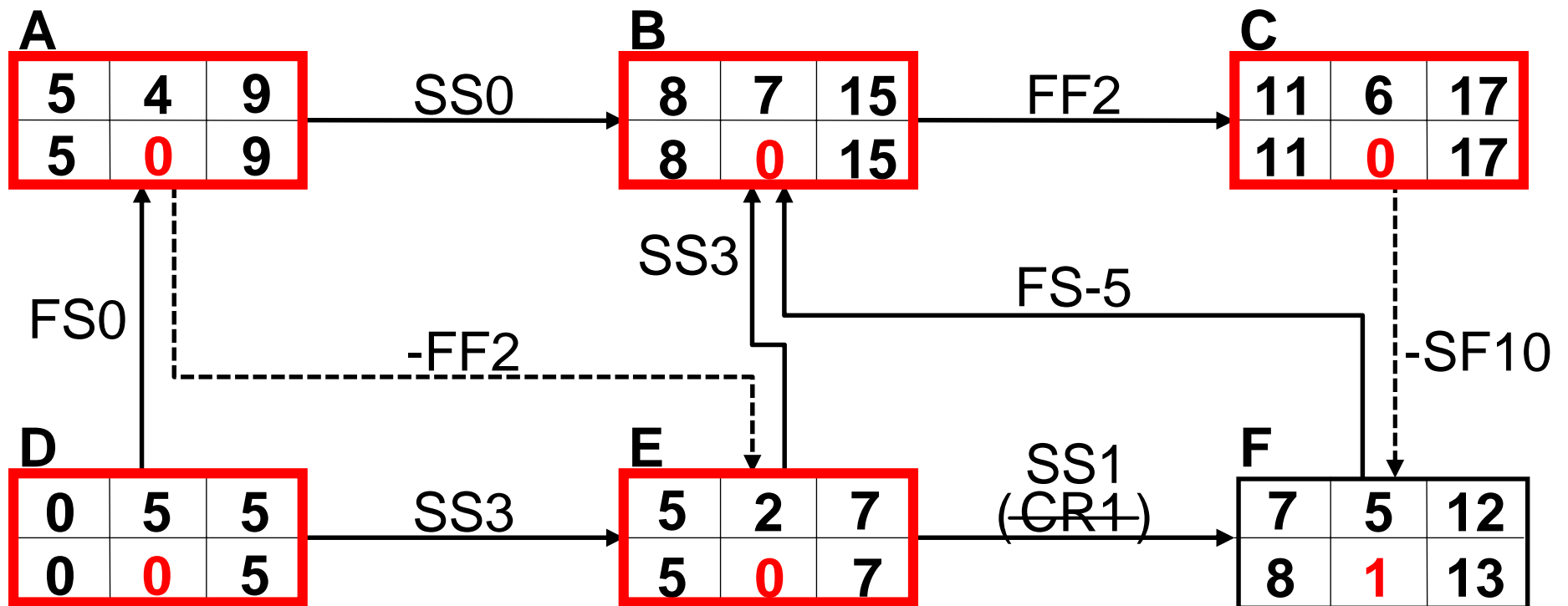

By definition: all activities having no any float are considered as critical ones
(Total float equals to zero)

3.2 Identifying critical relations (limitations, „arrows”)

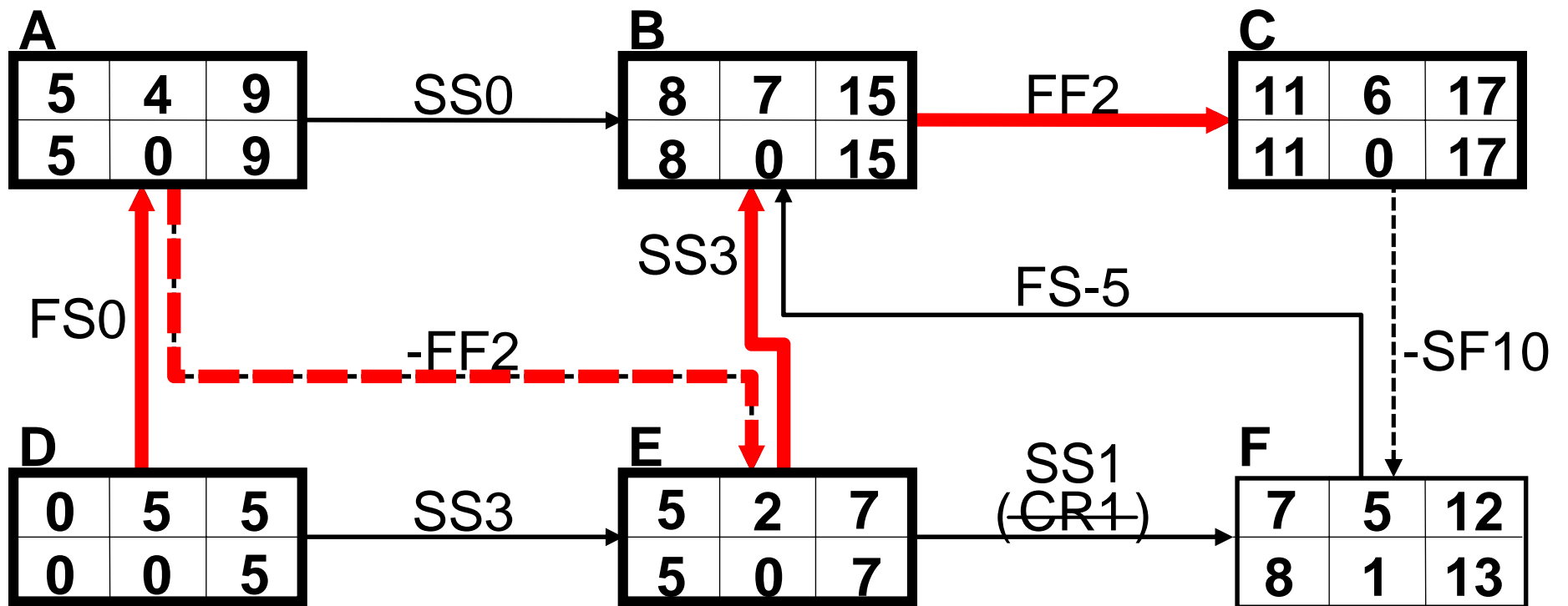

By definition: relations (limitations) between critical activities, having been satisfied on limit value (by equivalence) are considered as critical ones

3.3 Identifying (dominance-) types of critical activities

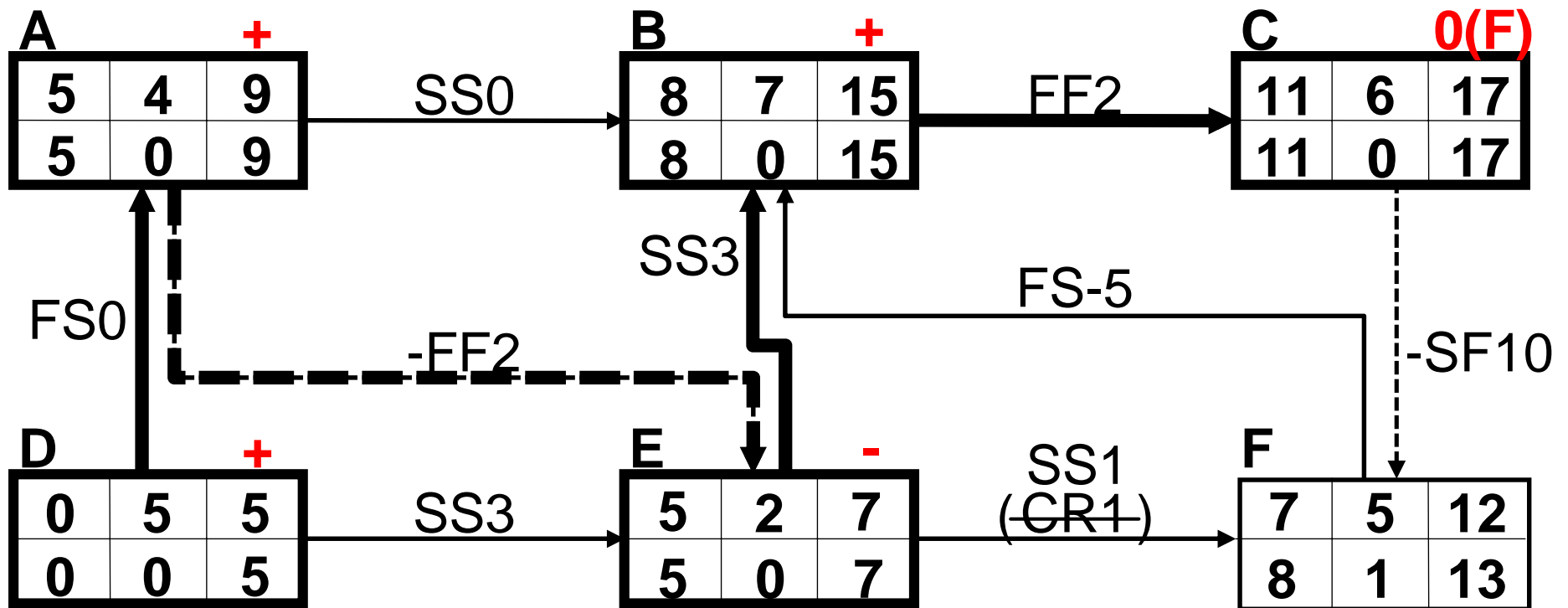

Type of dominance of critical activities (likely effect of modifying their duration by one unit) is determined by the entering and leaving points (start or finish) of related critical relations („arrows”) along „The Critical Path”.

3.4 Restoring original relation: CR1

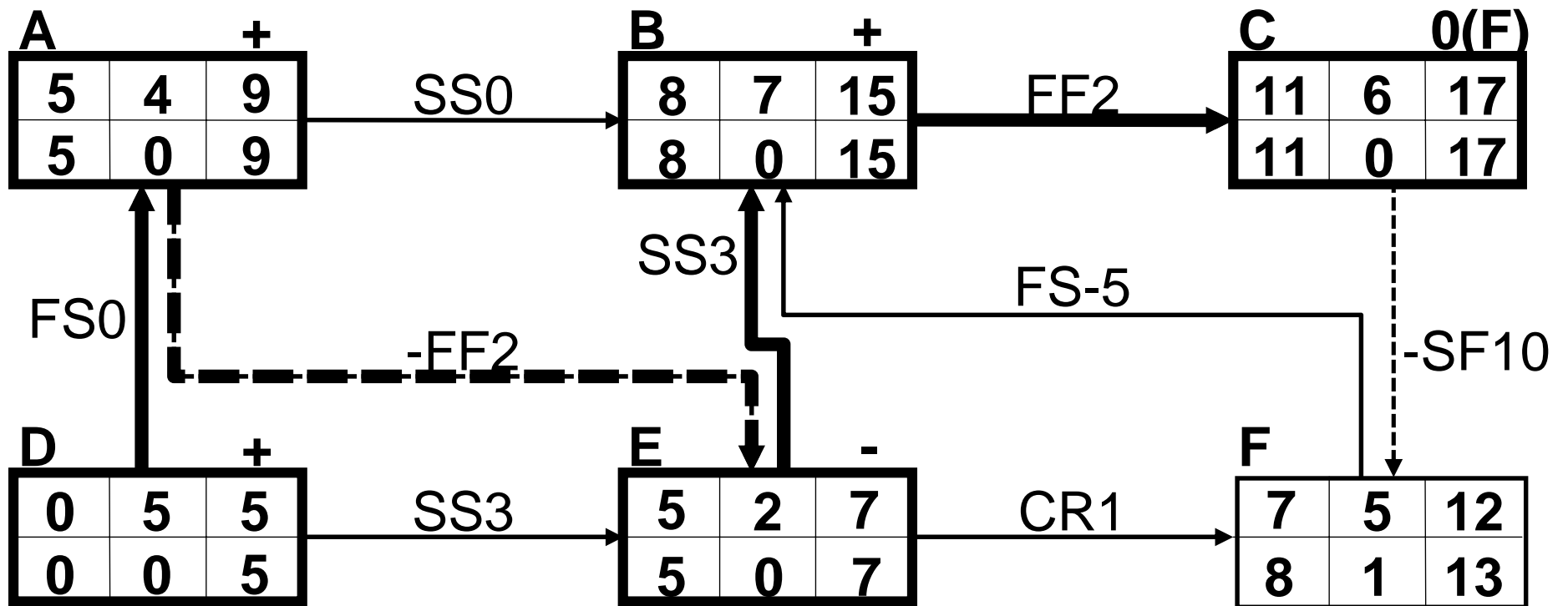

THE END